

Ultima Cellular Shade & Transitions Pleated Shade Installation Instructions

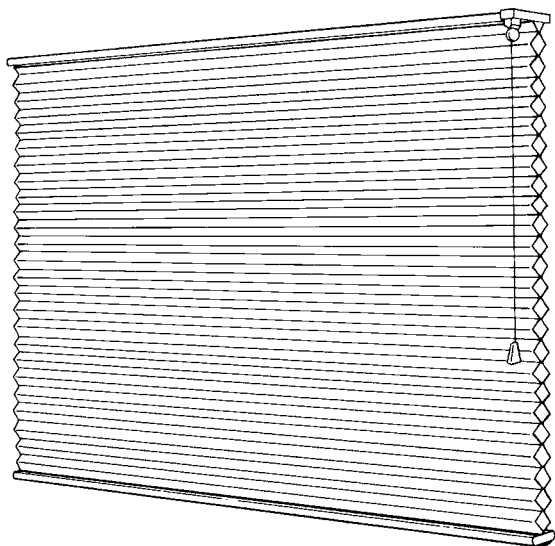

Transitions[®]

Ultima[®]

Congratulations on the purchase of your new window covering! 3 Day Blinds' products are an attractive choice for your home or office. Included with your purchase is all of the hardware you will need to successfully install your new shade. Please take a moment to read through these instructions before starting.

3 DAY BLINDS[®]

*America's Window Covering Specialists*SM

1-800-800-3DAY
www.3dayblinds.com

Getting Started

A few simple tools are required:

- Steel tape measure
- Power drill and drill bits (if desired)
- Flathead and Phillips screwdriver
- Pencil
- Level (for outside mount)
- Awl (or tool for starting a screw hole)

Included in your order is all the hardware necessary for a normal installation. Depending on the mounting surface, fasteners other than the screws provided may be required. Wall board and plaster require the use of anchors such as expansion or toggle bolts. Bricks, tile and stone need special plugs and drill bits. Wood should always be pre-drilled to avoid splitting.

Professional installation is also available at most 3 Day Blinds locations.

Standard Hardware

Mounting Brackets

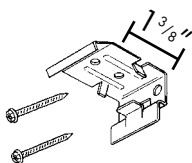

Ultima $\frac{3}{8}$ " Cellular Shade
Transitions Pleated Shade

- or -

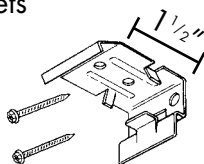

Ultima $\frac{3}{4}$ " Cellular Shade
Ultima Dual Cell Shade

Optional Hardware

Extension Bracket

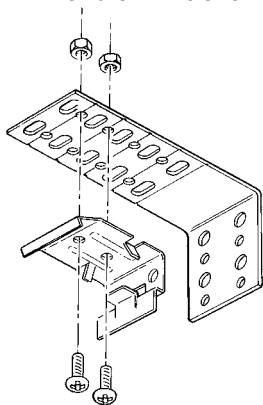

Spacers

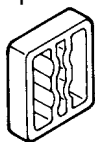

Hold Down Bracket

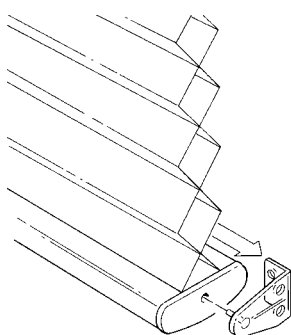

Bracket Information

Brackets should be installed at each end, with the centerline of the brackets positioned $\frac{1}{4}$ " from the ends. Depending upon the width of the shading, additional brackets may be required and will need to be evenly spaced between the two end brackets.

Blind Width	Number of Brackets
10" - 31"	2
31 $\frac{1}{8}$ " - 70"	3
70 $\frac{1}{8}$ " - 90"	4
90 $\frac{1}{8}$ " - 120"	5
120 $\frac{1}{8}$ " - 168"	6

Inside Mount

- 1 $\frac{3}{8}$ " of flat mounting surface is required to flush mount an Ultima $\frac{3}{8}$ " Cellular Shade or Transitions Pleated Shade.
- 1 $\frac{5}{8}$ " of flat mounting surface is required to flush mount an Ultima $\frac{3}{4}$ " or Dual Cellular Shade.

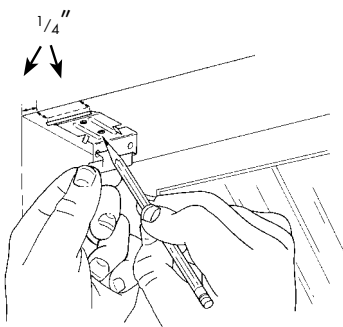

- Brackets should be installed $\frac{1}{4}$ " in from each corner of the window and $\frac{1}{4}$ " back from the front edge of the window casing.

- Proceed to "Shade Installation" on Page 5.

Outside Mount

NOTE: You will be using your shade with mounting brackets attached to the headrail to mark the position of the brackets on your wall or molding. DO NOT CUT the cellophane wrapping as the fabric or the cords supporting the shade may be inadvertently cut. Unwrap the cellophane and unwind the shade cord from around the headrail.

- Attach brackets to the headrail $\frac{1}{4}$ " from each end. If additional brackets are required they should be evenly spaced over the width of the headrail. Lower the shade to its full length. (See "Shade Operation" on Page 5.)

NOTE: If using extension brackets, attach mounting brackets to extension brackets with nuts and bolts before attaching brackets to headrail. (See "Optional Accessories" on Page 7.)

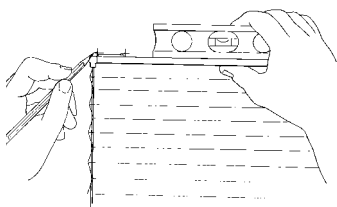

- Hold the shade up to the desired mounting position over the window. Once the shade is level, mark the wall or molding on either side and top of each mounting bracket.

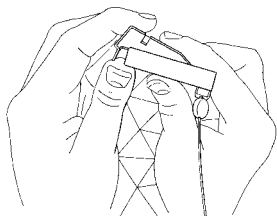

- Remove the mounting brackets from the headrail by pushing back and up on the "tail" of the bracket.

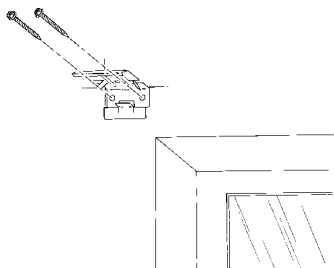

- 1" of flat mounting surface is required to mount your Ultima Cellular Shade or Transitions Pleated Shade.

- Proceed to "Shade Installation" on Page 5.

End Mount

An end mount is recommended for shades being installed with an arch top or for inside mount applications where there is no alternative mounting surface.

NOTE: You will be using your shade with mounting brackets attached to the headrail to mark the position of the brackets in your window opening. **DO NOT CUT** the cellophane wrapping as the fabric or cords supporting the shade may be inadvertently cut. Unwrap the cellophane and unwind the shade cord from around the headrail.

- Attach the mounting brackets to each extension bracket using the holes indicated in the diagram. Attach brackets to the headrail $\frac{1}{4}$ " from each end. Lower the shade to its full length. (See "Shade Operation" on Page 5.)

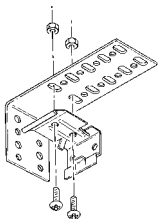

- With the mounting brackets attached, hold the shade up to the desired mounting position inside the window casing.

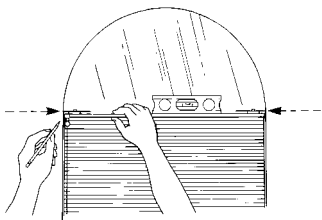

- Once the shade is level, recess the shade $\frac{1}{4}$ " from the front edge of the window casing and mark the wall on the front side and top edge of each extension bracket.

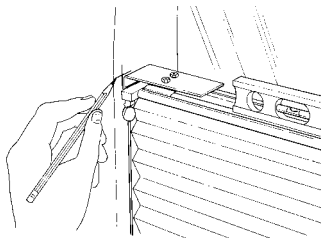

- Remove the mounting brackets from the headrail by pushing back and up on the "tail" of the bracket.

NOTE: Diagram does not show extension bracket.

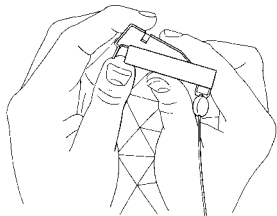

- Install an assembled end mounting bracket at each set of marks in your window opening.

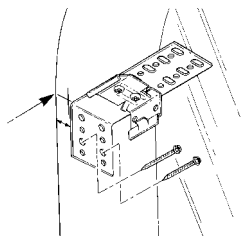

Shade Installation

If you have not already done so, unwrap the cellophane from around the shade. DO NOT CUT the cellophane as the fabric or the cords supporting the shade may be inadvertently cut. Also, unwind the shade cord and let it hang down in front of the shade.

NOTE: If you ordered a Top Down only shade, the lift cords have been pulled up through the top of the blind and wrapped to the headrail. When you unwrap the cellophane, the cords will be allowed to hang freely. Before installing the headrail, make sure the cords are not wrapped around the top of the headrail.

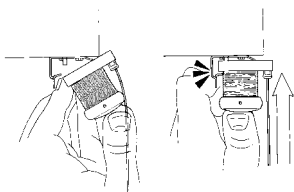

- Holding the shade up to the mounting brackets, hook the groove at the top and front of the headrail into the mounting bracket hooks.
- Rotate the headrail up and back until it snaps into place.

Shade Operation

Standard Shade

- To raise the shade, pull the draw cords down.
- To engage the lock, pull the cords down and toward the outside of the shade.
- To lower the shade, pull the draw cords down and toward the center of the shade and allow the cords to slide slowly through your hand.

Top Down Bottom Up

Follow "Standard Shade" instructions above for shade operation. This shade is different because it has two sets of cords. One set of cords controls the center rail the other is for the bottom rail.

Top Down

Follow "Standard Shade" instructions above for shade operation. This shade is slightly different because it has one set of cords that control the center rail only. The bottom rail is always in the down position.

Shade Removal

Draw the shade completely up. (See "Shade Operation", Page 5)

Inside Mount:

- Push back on the "tail" of each mounting bracket.

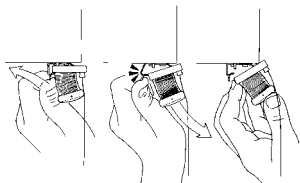

- Rotate the back of the headrail down and carefully lift the headrail off of the front hooks of the mounting brackets.

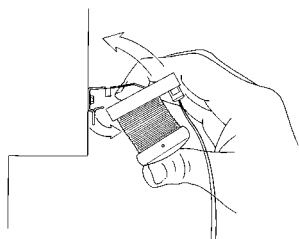

Outside Mount:

- While pinching the headrail and bottom rail together with both hands, gently but firmly rotate the headrail up until it pops out of the mounting brackets.

Optional Accessories

Extension Brackets — These are available in two sizes and are used to project the shade up to 3" from the mounting surface. Extension brackets are available at an additional charge and are ideal if your shade must clear an obstruction such as a sliding glass door handle or window crank. Extension brackets require a flat vertical mounting surface of at least 1³/₄".

To assemble and mount:

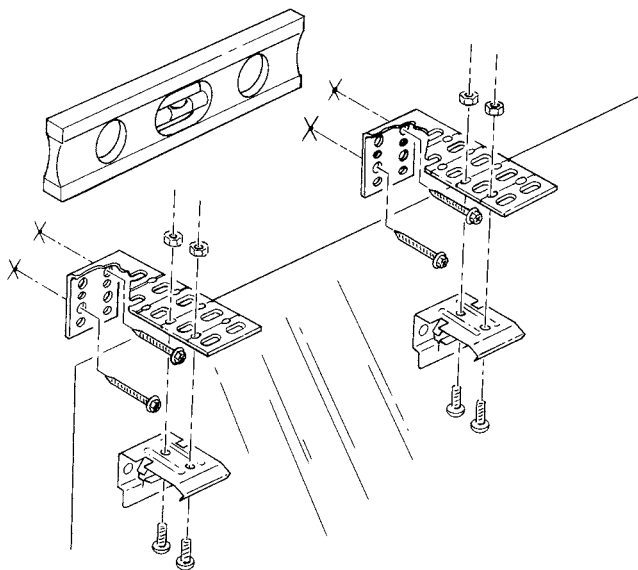

- Attach each mounting bracket to an extension bracket using the nuts bolts and washers provided.
- Mount the extension bracket to the wall per the instructions for an "Outside Mount" on Page 3 using a level and making certain that all mounting brackets are level and project the same distance from the mounting surface. For maximum stability, install the screws diagonally from one another.
- Install the shade per the directions for "Shade Installation" on Page 5.

Spacers — Available for use on windows with a projected molding. They are ³/₈" thick and allow the shade to be mounted flush with the outside edge of any standard window molding. They are free of charge and are available at any 3 Day Blinds showroom.

Hold Down Brackets — Used primarily on shades being mounted to doors or in motor homes. They are free of charge and are available at any 3 Day Blinds showroom. There are two small holes in the end caps that are covered by a thin plastic cover. Use the pin on the hold down bracket to punch out the front hole of each bottom rail end cap.

To install the hold down brackets:

- With the shade lowered to its full length, place the pin of each hold down bracket into the front hole in each end of the bottom rail.
- Using a pencil, mark the mounting surface through the holes in the hold down bracket. Make sure the hold down brackets are level and aligned with each other.
- Raise the shade and screw the hold down brackets into the mounting surface using the screws provided.

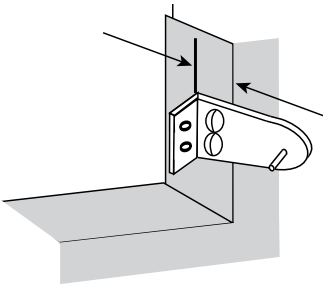

- Mount the hold down to the side or back of the window frame so that the pin lines up with the front hole in the bottom rail end cap with the shade fully lowered.

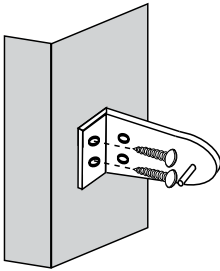

Lower the shade and flex the hold down bracket outward so that the pin can be inserted into the hole in the end cap.

Care & Cleaning

Frequent dusting or vacuuming with a soft brush attachment will help to ensure a long life for your shade. Soiled fabric can be gently spot cleaned with a mild soap and a soft damp sponge or cloth. Once cleaned, draw the shade up to its maximum open position and allow it to dry. This will help the shade to maintain its pleat retention.

3 Day Blinds also offers products specifically designed to safely and quickly clean fabric shades. Use of strong detergents, spot removers or ammonia based solutions will damage fabric shades and are not recommended.

WARNING



Young children can strangle in the loop of pull cords, chain and bead cords, and cords that run through window coverings. They can also wrap cords around their necks. To avoid strangulation and entanglement, keep cords out of reach of young children. Also,

1. Install safety devices that remove the cord loops or reduce access to cords, and
2. Move cribs and furniture away from window covering cords.

Limited Lifetime Warranty

3 Day Blinds, Inc., will repair or replace any part of the blind found to be defective in materials or workmanship at no cost to you. This warranty is limited to the original consumer purchaser of the blinds. There is no time limit to our warranty, excluding Essentials[®]-line products which come with a 1 year limited warranty. This warranty does not apply to any defect caused by improper installation, alteration, abuse, misuse or exposure to excess moisture. This warranty does not cover normal wear and tear such as the natural deterioration of fabric and changes in color that take place over time. This warranty does not cover products that exceed 3 Day Blinds' size recommendations. To obtain service, bring the product(s) in question to any 3 Day Blinds store with this warranty and your purchase invoice. This warranty gives you specific legal rights and you may also have other rights which vary from state to state.

3 DAY BLINDS[®]

America's Window Covering SpecialistsSM

1-800-800-3DAY
www.3dayblinds.com

PART # 000-023 REV 9-01
© COPYRIGHT SEPTEMBER 2001
3 DAY BLINDS, INC.