

CELLULAR & PLEATED SHADE ARCH

Installation Instructions

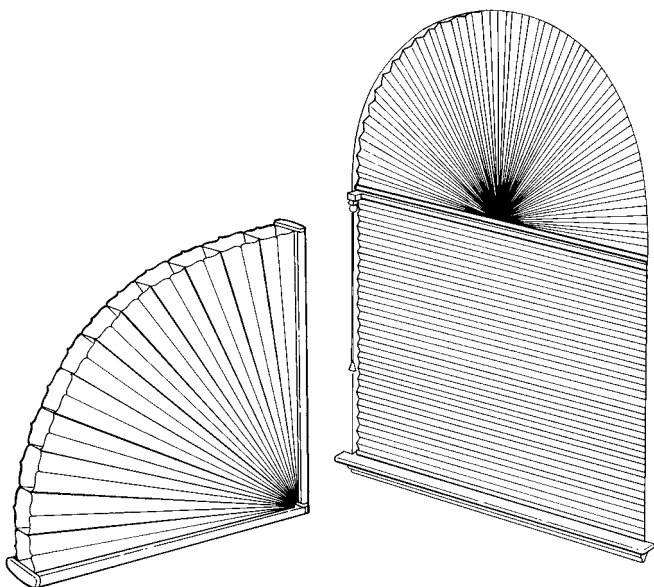

Transitions[®]
by **3 DAY BLINDS**

Ultima[®]

Congratulations on the purchase of your new cellular or pleated shade arch! 3 Day Blinds' products are an attractive choice for your home or office. Included with your purchase is all of the hardware you will need to successfully install your new shade. Please take a moment to read through these instructions before starting.

Bring Out Your Inner Decorator.

3 DAY BLINDS[®]

America's Window Covering Specialists® Since 1978

1-800-590-SHOP | www.3day.com

GETTING STARTED

A few simple tools are required:

- Steel tape measure
- Power drill and drill bits (if desired)
- Flathead and Phillips screwdriver
- Pencil
- Level (for outside mount)
- Awl (or tool for starting a screw hole)

Included in your order is all the hardware necessary for a normal installation. Depending on the mounting surface, fasteners other than the screws provided may be required. Wall board and plaster require the use of anchors such as expansion or toggle bolts. Bricks, tile or stone need special plugs and drill bits. Wood should always be pre-drilled to avoid splitting.

Professional installation is also available at most 3 Day Blinds locations.

STANDARD HARDWARE

Mounting Brackets

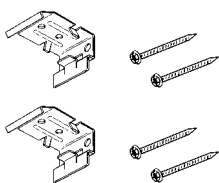

End Mount Brackets

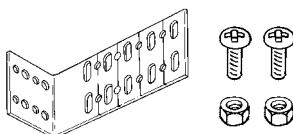

Arch Support Clip

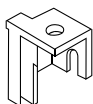

OPTIONAL HARDWARE

Hold Down Bracket

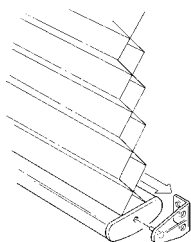

Spacer

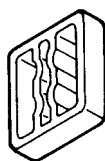

BRACKET INFORMATION

Shade Type	Mounting Brackets	End Mount Brackets
Shade with Arch Top — Inside Mount	4	2
Shade with Arch Top — Outside Mount	4	
Half Arch Stand Alone — Inside Mount	4	

Shade Width	Arch Support Clips
12" - 23"	1
23 1/8" - 42"	3

HALF ARCH

HALF ARCH INSTALLATION

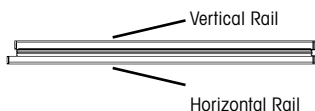
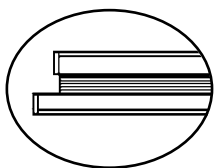

- Your half arch has been shipped in the closed position. When fanned, the rails will form a 90 degree angle. Note that the vertical rail is shorter than the horizontal rail.

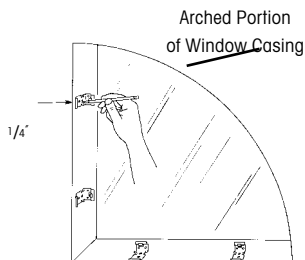

- 1 3/8" of flat mounting surface is required to flush mount an Ultima 3/8" Cellular Shade Half Arch.
- 1 1/2" of flat mounting surface is required to flush mount an Ultima 3/4" or Dual Cellular Shade Half Arch.

Install brackets 1/4" in from the front edge and equally spaced on the vertical and horizontal sides of the window opening.

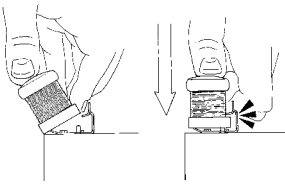

- Before fanning the shade, install the bottom rail onto the horizontal mounting clips by hooking the groove at the front of the rail into the mounting bracket hooks and rotate into place.

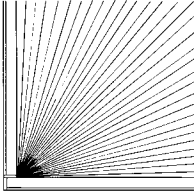

- Fan the shade so that the vertical rail rests upon the horizontal rail. Attach the vertical rail to the vertical brackets.

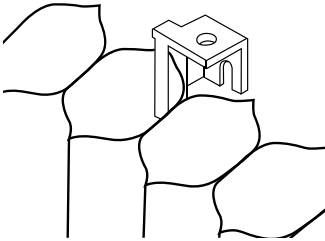

- Position one arch support clip at the center portion of the arch opening so that the clip holds a cell of the fabric. Install the arch support clip with a screw through the top of the clip. If required, space additional clips evenly along the arch. Place the appropriate cell of fabric into the arch support bracket(s).

Note: To avoid damaging your shade, remove the shade from the vertical brackets and collapse the arch while installing the arch support clips.

HALF ARCH SHADE REMOVAL

Push back on the "tail" of the bracket.

Starting with the vertical rail, rotate the back of the shade towards you and carefully lift the rail off of the front hooks of the mounting brackets. Repeat for horizontal rail.

ARCH TOP WITH ASSOCIATED RECTANGULAR SHADE

ARCH TOP ASSEMBLY

Your arch top shade has been shipped in the closed position and inserted into it's own bottom rail. Remove the endcap located opposite the arch stack.

- One side of the arch has already been attached to an adhesive strip which has been inserted into the bottom rail. Slide the strip with the arch attached out of the bottom rail until the arch is even with the end of the bottom rail.

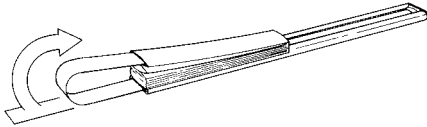
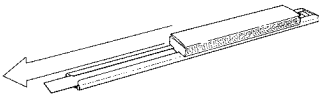

- **For Ultima 3/4" and Dual Cell only:**

Insert the loose end of the adhesive strip into the top cell of the arch. DO NOT remove the protective covering. Continue inserting the strip into the arch until there is no remaining slack.

- **For Ultima 3/8" Cell only:**

The top cell has been slit to accommodate the adhesive strip. Remove the protective covering on the loose end of the adhesive strip. Fold the strip over so that it adheres to the top of the slit cell.

- **For Transitions Pleated Shade only:**

Remove the protective covering on the remaining adhesive strip. Fold the strip over so that it adheres to the top pleat on the stack.

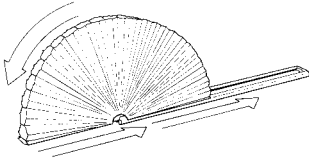

- Open the arch to its fully fanned position and gently insert the remaining half of the arch into the bottom rail. Only the very last cell which encases the adhesive strip should be inserted into the bottom rail.

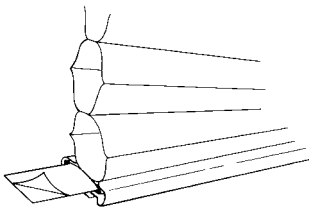

- **For Ultima 3/4" and Dual Cell only:** Gently remove the protective covering from the last 2" of the adhesive strip. Gently press the cellular arch fabric against the adhesive to hold your arch securely in place.

- Replace the end cap on the bottom rail of your fully assembled arch.

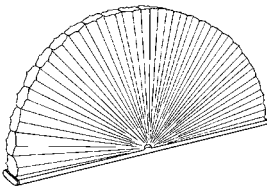

INSIDE MOUNT SHADE WITH ARCH TOP

You will be using your assembled arch top with mounting brackets attached to the bottom rail to mark the position of the brackets on your wall or molding.

An inside mount shade with an arch top requires a special type of installation to keep the shade and the arch in close proximity to each other. This type of installation requires an end mount bracket system.

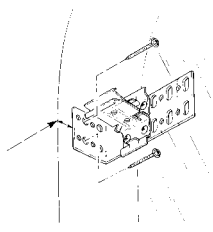
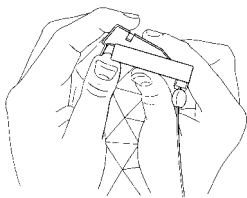
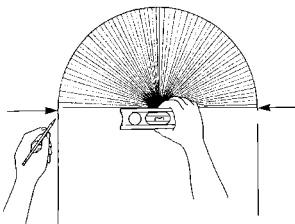
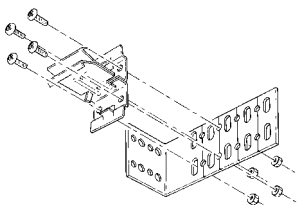
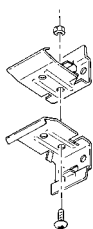

- Attach two mounting brackets together with one nut and bolt.
- Attach the mounting brackets to the end mount brackets using four nuts and bolts. Use the set of holes closest to the corner of the end bracket. Attach the assembled brackets to each end of the arch top bottom rail.
- Hold the arch top up to the desired mounting position inside the window. Once the bottom rail is level, mark the wall or molding on the front side and bottom edge of each mounting bracket.
- Remove the mounting brackets from the arch bottom rail by pushing back and up on the "tail" of the bracket.
- 1 $\frac{3}{8}$ " of flat mounting surface is required to flush mount an Ultima $\frac{3}{8}$ " Cellular Shade or Transitions Pleated Shade.
- 1 $\frac{1}{2}$ " of flat mounting surface is required to flush mount an Ultima $\frac{3}{4}$ " or Dual Cellular Shade.
- Proceed to "Rectangular Shade Installation" on Page 7 before installing arch top, Page 8.

OUTSIDE MOUNT SHADE WITH ARCH TOP

NOTE: You will be using your shade with mounting brackets attached to the headrail to mark the position of the brackets on your wall or molding. DO NOT CUT the cellophane wrapping as the fabric or cords supporting the shade may be inadvertently cut. Unwrap the cellophane and unwind the shade cord from around the headrail.

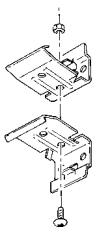

- Attach two of the mounting brackets to each other using one nut and bolt.
- Attach assembled brackets to the headrail $\frac{1}{4}$ " from each end. Lower the shade to it's full length. (See "Rectangular Shade Operation", Page 7.)

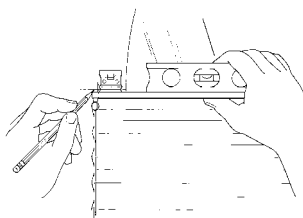

- Hold the shade up to the desired mounting position over the window. Once the shade is level, mark the wall or molding on either side and top edge of each mounting bracket.

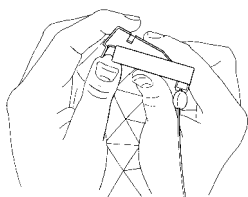

- Remove the mounting brackets from the headrail by pushing back and up on the "tail" of the bracket.

- 2" of flat mounting surface is required to mount the assembled brackets.

- Proceed to "Rectangular Shade Installation" on Page 7.

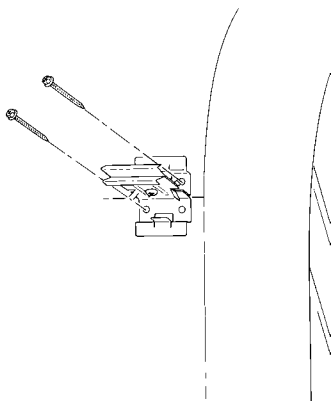

RECTANGULAR SHADE INSTALLATION

If you have not already done so, unwrap the cellophane from around the shade. DO NOT cut the cellophane as the fabric or the cords supporting the shade may be inadvertently cut. Also, unwind the shade cord and let it hang down in front of the shade.

NOTE: If you ordered a Top Down only shade, the lift cords have been pulled up through the top of the blind and wrapped to the headrail. When you unwrap the cellophane, the cords will be allowed to hang freely. Before installing the headrail, make sure the cords are not wrapped around the top of the headrail.

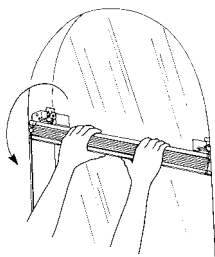

- Holding the shade up to the mounting brackets, hook the groove at the top and front of the headrail into the mounting bracket hooks.

- Rotate the headrail up and back until it snaps into place.

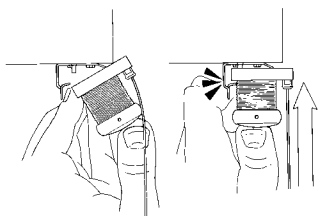

RECTANGULAR SHADE OPERATION

Standard Shade

- To raise the shade, pull the draw cords down.
- To engage the lock, pull the cords down and toward the outside of the shade.
- To lower the shade, pull the draw cords down and toward the center of the shade and allow the cords to slide slowly through your hand.

Top Down Bottom Up

- * Follow "Standard Shade" instructions above for shade operation. This shade is different because it has two sets of cords. One set of cords controls the center rail the other is for the bottom rail.

Top Down

- * Follow "Standard Shade" instructions above for shade operation. This shade is slightly different because it has one set of cords that control the center rail only. The bottom rail is always in the down position.

ARCH TOP INSTALLATION

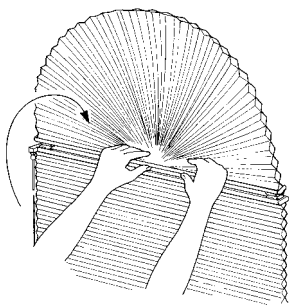

- Install the bottom rail of the cellular arch into the brackets located at the top of the headrail of your previously installed shade.
- Position one arch support clip at the center portion of the arch opening so that the clip holds a cell of the fabric. Install the arch support clip with a screw through the top of the clip (for inside mount) or the back of the clip (for outside mount). If required, space additional clips evenly along the arch. Place the appropriate cell of fabric into the arch support bracket(s).

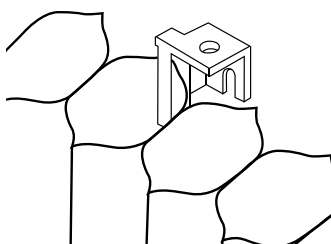

Note: To avoid damaging your shade, allow the shade to gently fall forward out of the way while installing the arch support clips.

RECTANGULAR SHADE REMOVAL

Draw the shade completely up. (See "Rectangular Shade Operation", Page 7.)

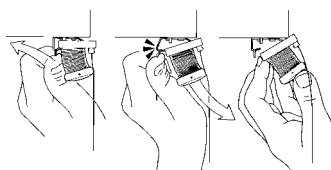

Inside Mount:

- Push back on the "tail" of each mounting bracket.
- Rotate the back of the headrail down and carefully lift the headrail off of the front hooks of the mounting brackets.

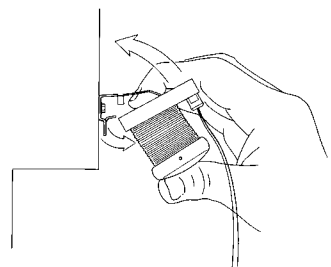

Outside Mount:

- While pinching the headrail and bottom rail together with both hands, gently but firmly rotate the headrail up until it pops out of the mounting brackets.

OPTIONAL ACCESSORIES

Extension Brackets — These are available in two sizes and are used to project the shade up to 3" from the mounting surface. Extension brackets are available at an additional charge and are ideal if your shade must clear an obstruction such as a sliding glass door handle or window crank. Extension brackets require a flat vertical mounting surface of at least 1 3/4".

To assemble and mount:

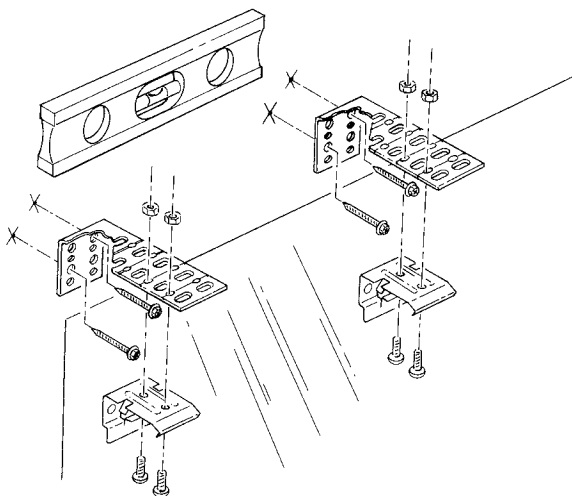

- Attach each mounting bracket to an extension bracket using the nuts bolts and washers provided.
- Mount the extension bracket to the wall per the instructions for an "Outside Mount" on Page 6 using a level and making certain that all mounting brackets are level and project the same distance from the mounting surface. For maximum stability, install the screws diagonally from one another.
- Install the shade per the directions for "Rectangular Shade Installation" on Page 7.

Spacers — Available for use on windows with a projected molding. They are 3/8" thick and allow the shade to be mounted flush with the outside edge of any standard window molding. They are free of charge and are available at any 3 Day Blinds showroom.

Hold Down Brackets — Used primarily on shades being mounted to doors or in motor homes. They are free of charge and are available at any 3 Day Blinds showroom. There are two small holes in the end caps that are covered by a thin plastic cover. Use the pin on the hold down bracket to punch out the front hole of each bottom rail end cap.

To install the hold down brackets:

- With the shade lowered to its full length, place the pin of each hold down bracket into the front hole in each end of the bottom rail.
- Using a pencil, mark the mounting surface through the holes in the hold down bracket. Make sure the hold down brackets are level and aligned with each other.
- Raise the shade and screw the hold down brackets into the mounting surface using the screws provided.
- Mount the hold down to the side or back of the window frame so that the pin lines up with the front hole in the bottom rail endcap with the shade fully lowered

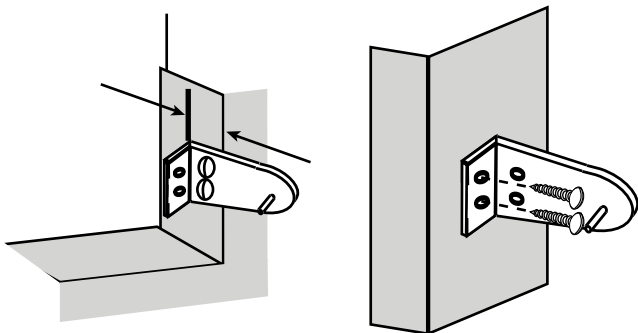

Lower the shade and flex the hold down bracket outward so that the pin can be inserted into the hole in the end cap.

CARE AND CLEANING

Frequent dusting or vacuuming with a soft brush attachment will help to ensure a long life for your shade. Soiled fabric can be gently spot cleaned with a mild soap and a soft damp sponge or cloth. Once cleaned, draw the shade up to its maximum open position and allow it to dry. This will help the shade to maintain its pleat retention.

3 Day Blinds also offers products specifically designed to safely and quickly clean fabric shades. Use of strong detergents, spot removers or ammonia based solutions will damage fabric shades and are not recommended.



WARNING

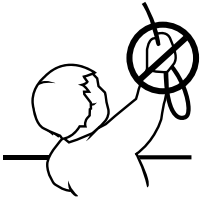

Young children can strangle in the loop of pull cords, chain and bead cords, and cords that run through window coverings. They can also wrap cords around their necks. To avoid strangulation and entanglement, keep cords out of reach of young children. Also,

1. Install safety devices that remove the cord loops or reduce access to cords, and
2. Move cribs and furniture away from window covering cords.

LIMITED LIFETIME WARRANTY

3 Day Blinds, Inc., will repair or replace any part of the blind found to be defective in materials or workmanship at no cost to you. This warranty is limited to the original consumer purchaser of the blinds. There is no time limit to our warranty, excluding Essentials® line products which come with a 1 year limited warranty. This warranty does not apply to any defect caused by improper installation, alteration, abuse, misuse or exposure to excess moisture. This warranty does not cover normal wear and tear such as the natural deterioration of fabric and changes in color that take place over time. This warranty does not cover products that exceed 3 Day Blinds' size recommendations. To obtain service, bring the product(s) in question to any 3 Day Blinds store with this warranty and your purchase invoice. This warranty gives you specific legal rights and you may also have other rights which vary from state to state.

Bring Out Your Inner Decorator.®

3 DAY BLINDS.®

America's Window Covering Specialists.® Since 1978

1-800-590-SHOP | www.3day.com